

Threaded Elbow

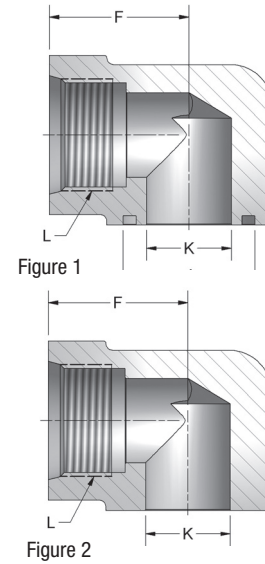
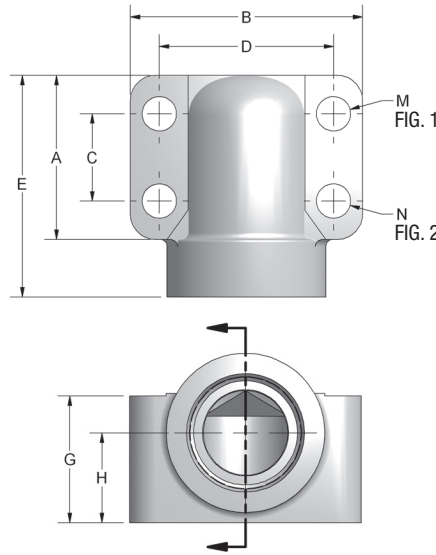
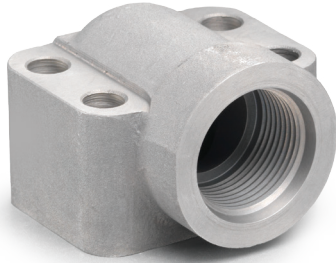

CODE 61 ELBOW SAE STRAIGHT THREAD																	
PART NO. O-RING FIG. 1	PART NO. FLAT FACE FIG. 2	PAD SIZE	A	B	C	D	E	F	G	H	J	K	L	M	N UNC-2B	MOUNTING HARDWARE	
																O-RING	SHCS
W164-12-12	W165-12-12	.75	1.69	2.56	.875	1.875	2.28	1.44	1.25	.875	1.250	.752	1-1/16-12	.406	3/8-16	214	3/8-16X2.00
W164-16-16	W165-16-16	1.00	1.94	2.75	1.031	2.062	2.62	1.66	1.50	1.062	1.560	1.002	1-5/16-12	.406	3/8-16	219	3/8-16X2.25
W164-20-20	W165-20-20	1.25	2.19	3.12	1.188	2.312	3.00	1.91	1.81	1.188	1.750	1.252	1-5/8-12	.469	7/16-14	222	7/16-14X2.75
W164-24-24	W165-24-24	1.50	2.56	3.69	1.406	2.750	3.33	2.05	2.00	1.312	2.115	1.502	1-7/8-12	.531	1/2-13	225	1/2-13X3.00
W164-32-32	W165-32-32	2.00	3.06	4.33	1.688	3.062	3.81	2.28	2.50	1.656	1.490	2.002	2-1/2-12	.531	1/2-13	228	1/2-13X3.50

CODE 61 ELBOW NPTF THREAD																	
PART NO. O-RING FIG. 1	PART NO. FLAT FACE FIG. 2	PAD SIZE	A	B	C	D	E	F	G	H	J	K	L	M	N UNC-2B	MOUNTING HARDWARE	
																O-RING	SHCS
W168-12-12	W170-12-12	.75	1.69	2.56	.875	1.875	2.28	1.44	1.25	.875	1.250	.752	.75	.406	3/8-16	214	3/8-16X2.00
W168-16-16	W170-16-16	1.00	1.94	2.75	1.031	2.062	2.62	1.66	1.50	1.062	1.560	1.002	1.00	.406	3/8-16	219	3/8-16X2.25
W168-20-20	W170-20-20	1.25	2.19	3.12	1.188	2.312	3.00	1.91	1.81	1.188	1.750	1.252	1.25	.469	7/16-14	222	7/16-14X2.75
W168-24-24	W170-24-24	1.50	2.56	3.69	1.406	2.750	3.33	2.05	2.00	1.312	2.115	1.502	1.50	.531	1/2-13	225	1/2-13X3.00
W168-32-32	W170-32-32	2.00	3.06	4.33	1.688	3.062	3.81	2.28	2.50	1.656	2.490	2.002	2.00	.531	1/2-13	228	1/2-13X3.50

CODE 62 ELBOW SAE STRAIGHT THREAD																	
PART NO. O-RING FIG. 1	PART NO. FLAT FACE FIG. 2	PAD SIZE	A	B	C	D	E	F	G	H	J	K	L	M	N UNC-2B	MOUNTING HARDWARE	
																O-RING	SHCS
W184-12-12	W185-12-12	.75	1.94	2.75	.937	2.000	2.62	1.66	1.50	1.062	1.250	.752	1-1/16-12	.406	3/8-16	214	3/8-16X2.25
W184-16-16	W185-16-16	1.00	2.19	3.12	1.093	2.250	3.00	1.91	1.81	1.188	1.560	1.002	1-5/16-12	.492	7/16-14	219	7/16-14X2.50
W184-20-20	W185-20-20	1.25	2.56	3.69	1.250	2.625	3.32	2.05	2.00	1.312	1.750	1.252	1-5/8-12	.531	1/2-13	222	1/2-13X3.00
W184-24-24	W185-24-24	1.50	3.06	4.33	1.437	3.125	3.81	2.28	2.50	1.656	2.115	1.502	1-7/8-12	.656	5/8-11	225	5/8-11X3.50

CODE 62 ELBOW NPTF THREAD																	
PART NO. O-RING FIG. 1	PART NO. FLAT FACE FIG. 2	PAD SIZE	A	B	C	D	E	F	G	H	J	K	L	M	N UNC-2B	MOUNTING HARDWARE	
																O-RING	SHCS
W188-12-12	W180-12-12	.75	1.94	2.75	.937	2.000	2.62	1.66	1.50	1.062	1.250	.752	.75	.406	3/8-16	214	3/8-16X2.25
W188-16-16	W180-16-16	1.00	2.19	3.12	1.093	2.250	3.00	1.91	1.81	1.188	1.560	1.002	1.00	.492	7/16-14	219	7/16-14X2.50
W188-20-20	W180-20-20	1.25	2.56	3.69	1.250	2.625	3.32	2.05	2.00	1.312	1.750	1.252	1.25	.531	1/2-13	222	1/2-13X3.00
W188-24-24	W180-24-24	1.50	3.06	4.33	1.437	3.125	3.81	2.28	2.50	1.656	2.115	1.502	1.50	.656	5/8-11	225	5/8-11X3.50

Mounting kit available on O-Ring grooved flanges by simply adding suffix letter 'U' to part number.