

Return Filters
E 303 · E 503 · E 703

Tank top mounting · Connection up to SAE 2½ · Nominal flow rate up to 900 l/min / 237.8 gpm

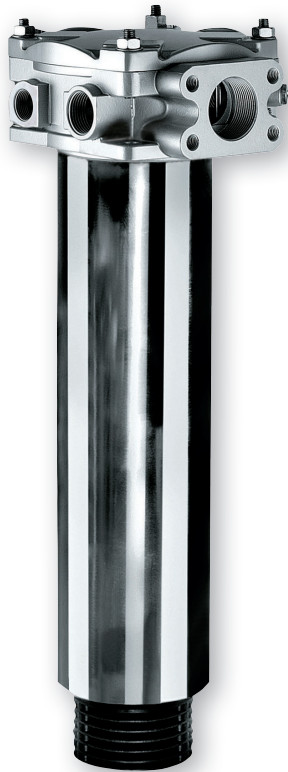

Return Filters E 503

Description
Application

In the return line circuits of hydraulic systems.

Performance features
Protection against wear:

By means of filter elements that even in full-flow filtration meet the highest demands regarding cleanliness classes.

Protection against malfunction:

By means of full-flow filtration in the system return, the pumps above all are protected from dirt particles remaining in the system after assembly, repairs, or which are generated by wear or enter the system from outside.

Special features

- › By-pass valve:
The location close to the inlet port prevents dirt particles retained by the filter element from entering into the clean oil side.
- › Removable bowl:
In case of maintenance the filter bowl is removed together with the filter element - therefore dirt particles are not flushed back into the tank.

Filter elements

Flow direction from outside to center.

The star-shaped pleating of the filter material results in:

- › large filter surfaces
- › low pressure drop
- › high dirt-holding capacities
- › long service life

Filter maintenance

By using a clogging indicator the correct moment for maintenance is stated and guarantees the optimum utilization of the filter life.

Materials

Filter head cover:	Steel
Filter head:	Aluminum alloy
Filter bowl:	Steel
Seals:	NBR (FPM on request)
Filter media:	EXAPOR®MAX2 - inorganic multi-layer microfiber web

Materials

Filter head cover:	Steel
Filter head:	Aluminum alloy
Filter bowl:	Steel
Seals:	NBR (FPM on request)
Filter media:	EXAPOR®MAX2 - inorganic multi-layer microfiber web

Clogging indicator

Electrical and / or optical clogging indicators are available on request. Dimensions and technical data see catalog sheet 60.20.

Accessories

Extension pipes and diffusers on the bowl outlet are available on request.

Extension pipe:

A correct extension pipe length ensures oil outlet below minimum oil level and prevents foaming.

Diffuser:

Diffusers reduce oil velocity and direct the oil to 90° outlet flow. This function prevents also oil foaming and whirling up of solid particles settled at the tank bottom.

Characteristics

Nominal flow

Up to 900 l/min / 237.8 gpm (see Selection Chart, column 2). The nominal flow rates indicated by ARGO-HYTOS are based on the following features:

- › closed by-pass valve at $v \leq 200 \text{ mm}^2/\text{s} / 927 \text{ SUS}$
- › element service life > 1000 operating hours at an average fluid contamination of 0.07 g per l/min / 0.27 g per gpm flow volume
- › flow velocity in the connection lines $\leq 4.5 \text{ m/s} / 14.8 \text{ ft/s}$

Connection

- › SAE standard J514
- › SAE-flange (3000 psi)

Sizes see Selection Chart, column 6, (other port threads on request).

Filter fineness

5 $\mu\text{m(c)}$... 16 $\mu\text{m(c)}$
 β -values according to ISO 16889
(see Selection Chart, column 4 and diagram Dx)

Dirt-holding capacity

Values in g test dust ISO MTD according to ISO 16889
(see Selection Chart, column 5).

Hydraulic fluids

Mineral oil and biodegradable fluids
(HEES and HETG, see info-sheet 00.20).

Temperature range

-30 °C ... +100 °C (temporary -40 °C ... +120 °C)
-22 °F ... +212 °F (temporary -40 °F ... +248 °F)

Viscosity at nominal flow rate

- › at operating temperature: $v < 60 \text{ mm}^2/\text{s} / 280 \text{ SUS}$
- › as starting viscosity: $v_{\text{max}} = 1200 \text{ mm}^2/\text{s} / 5560 \text{ SUS}$
- › at initial operation:
The recommended starting viscosity can be read from the diagram D (pressure drop as a function of the kinematic viscosity) as follows: Find the 70% Δp of the cracking pressure of the by-pass valve on the vertical axis. Draw a horizontal line so that it intersects the Δp curve at a point. Read this point on the horizontal axis for the viscosity.

Operating pressure

Max. 10 bar / 145 psi

Mounting position

Preferably vertical, outlet downwards.

Δp-curves for complete filters in Selection Chart, column 3

D1 Pressure drop as a function of the **flow volume** at $v = 35 \text{ mm}^2/\text{s} / 162 \text{ SUS}$ (0 = casing empty)

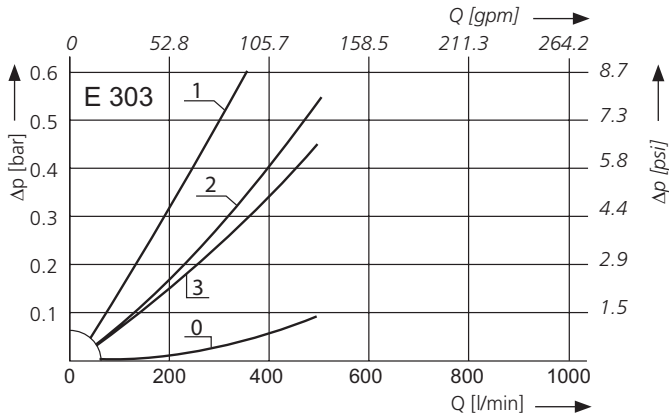

Pressure drop as a function of the **kinematic viscosity** at nominal flow

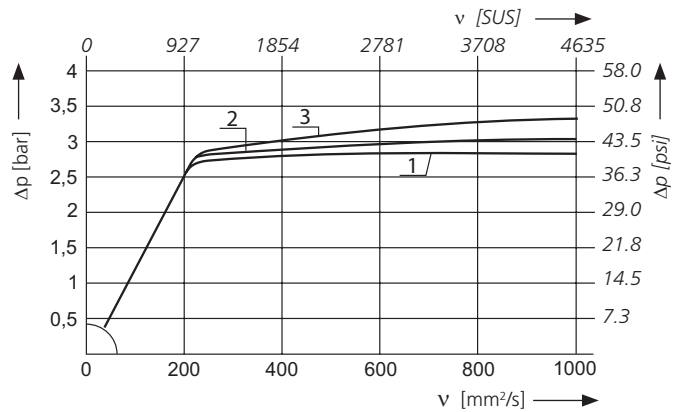

D2 Pressure drop as a function of the **flow volume** at $v = 35 \text{ mm}^2/\text{s} / 162 \text{ SUS}$ (0 = casing empty)

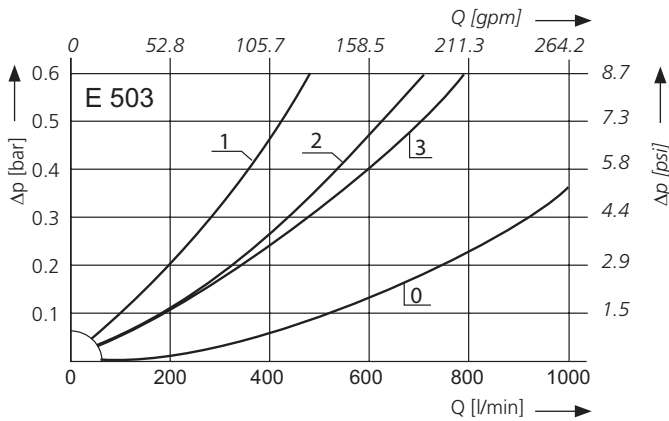

Pressure drop as a function of the **kinematic viscosity** at nominal flow

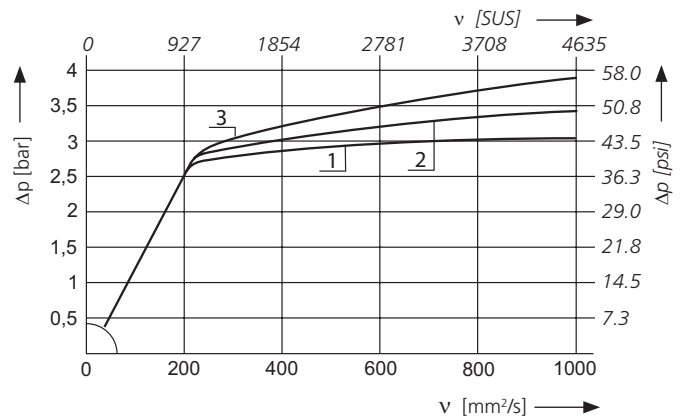

D3 Pressure drop as a function of the **flow volume** at $v = 35 \text{ mm}^2/\text{s} / 162 \text{ SUS}$ (0 = casing empty)

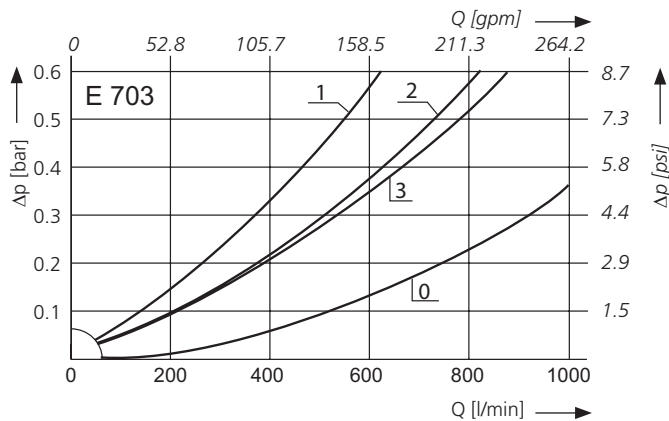

Pressure drop as a function of the **kinematic viscosity** at nominal flow

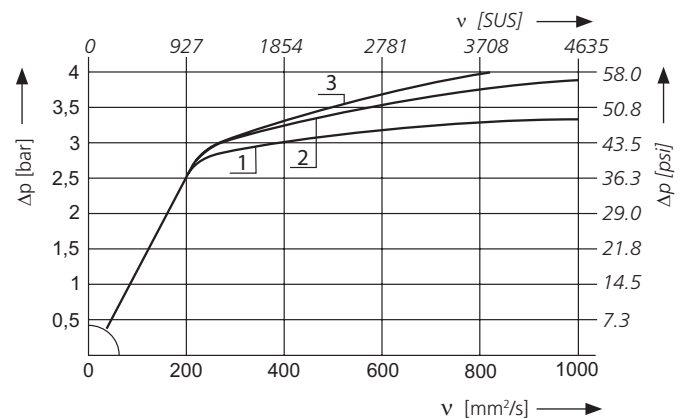

Filter fineness curves in Selection Chart, column 4

Dx Filtration ratio β as a function of particle size x obtained by the Multi-Pass-Test according to ISO 16889

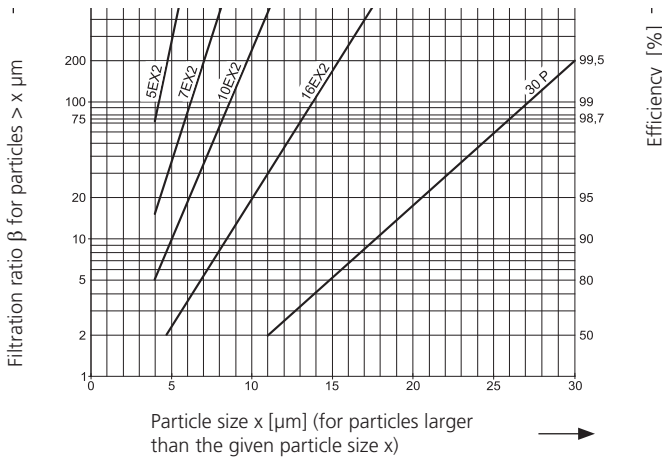

The abbreviations represent the following β -values resp. finenesses:

For EXAPOR[®]MAX 2 and Paper elements:

- 5EX2 = $\beta_{5(c)} = 200$ EXAPOR[®]MAX 2
- 7EX2 = $\beta_{7(c)} = 200$ EXAPOR[®]MAX 2
- 10EX2 = $\beta_{10(c)} = 200$ EXAPOR[®]MAX 2
- 16EX2 = $\beta_{16(c)} = 200$ EXAPOR[®]MAX 2
- 30P = $\beta_{30(c)} = 200$ Paper

Based on the structure of the filter media of the 30P paper elements, deviations from the printed curves are quite probable.

For screen elements:

- 40S = screen material with mesh size 40 μ m
- 60S = screen material with mesh size 60 μ m
- 100S = screen material with mesh size 100 μ m

Tolerances for mesh size according to DIN 4189.

For special applications, finenesses differing from these curves are also available by using special composed filter media.

Selection Chart

Part No.	Nominal flow rate ²	Pressure drop diagram D (curve no.)	Filter fineness see Diagr. Dx	Dirt-holding capacity	Connection A (A ₁ ... A ₄) ³	Cracking Pressure of by-pass	Symbol	Replacement filter element Part no.	Weight	Remarks
	l/min			g		bar			kg	
1	2	3	4	5	6	7	8	9	10	11
E 303-453	220	D1/1	5EX2	91	2 x G1¼ / SAE1½, G¾ + G1	2.5	2	V2.1425-23	8.9	-
E 303-456¹	350	D1/2	10EX2	120	2 x G1¼ / SAE1½, G¾ + G1	2.5	2	V2.1425-26	8.9	-
E 303-458¹	500	D1/3	16EX2	130	2 x G1¼ / SAE1½, G¾ + G1	2.5	2	V2.1425-28	8.9	-
E 503-453	350	D2/1	5EX2	150	2 x G1¼ / SAE1½, G¾ + G1	2.5	2	V2.1440-23	11.7	-
E 503-456¹	540	D2/2	10EX2	200	2 x G1¼ / SAE1½, G¾ + G1	2.5	2	V2.1440-26	11.7	-
E 503-458¹	750	D2/3	16EX2	200	2 x G1¼ / SAE1½, G¾ + G1	2.5	2	V2.1440-28	11.7	-
E 703-453	500	D3/1	5EX2	230	2 x G1¼ / SAE1½, G¾ + G1	2.5	2	V2.1460-23	15.4	-
E 703-456¹	740	D3/2	10EX2	300	2 x G1¼ / SAE1½, G¾ + G1	2.5	2	V2.1460-26	15.4	-
E 703-458¹	900	D3/3	16EX2	310	2 x G1¼ / SAE1½, G¾ + G1	2.5	2	V2.1460-28	15.4	-

¹ Preferred type, no minimum order quantity required

² The individual flow rates must be matched to the connections

³ Connection G1 (A₄) with locking screw

⁴ On request an outlet diffuser can be combined with an extension pipe

All filters are delivered with a plugged clogging indicator connection M12 x 1.5 (mounting holes for differential pressure switches on request). As clogging indicators either manometers or electrical pressure switches can be used. Two different head pieces with three various connecting options are available. All filters can also be supplied with an outlet diffuser. Optional extension pipes adapt the filter length to various tank depths. For ordering of accessories please use the below mentioned codes.

Order example: The filter E 703-256 has to be supplied with 2 connections (A and A₄) and an extension pipe for 800 m (31.5 inch) length

Order description:

E 703- 256 / RV / EV 800

Connections:

two various options are available

two connections² (A und A₄)³ - SAE2½ und G1 _____ 2 _____

four connections² (A₁, A₂, A₃ und A₄) - 2 x G1¼ / SAE1½, G¾ und G1 _____ 4 _____

Bowl outlet⁴:

two various options are available

VD - Outlet diffuser, RV - extension pipe _____

Extension pipe⁴:

four various lengths are available

EV = K + 64 (2.52 inch) / + 164 (6.46 inch) / + 264 (10.39 inch) / + 454 (17.87 inch) _____

(see section dimensions and measurements)

For the appropriate clogging indicators see catalog sheet 60.20.

Remarks:

- › The switching pressure of the electrical pressure switch has always to be lower than the cracking pressure of the by-pass valve (see Selection Chart, column 7).
- › Clogging indicators are optional and always delivered detached from the filter.
- › The filters listed in this chart are standard filters. Other designs available on request.

Selection Chart

Part No.	Nominal flow rate ²	Pressure drop diagram D (curve no.)	Filter fineness see Diagr. Dx	Dirt-holding capacity	Connection A and A ₄ (SAE (3000 psi))	Cracking Pressure of by-pass	Symbol	Replacement filter element Part no.	Weight	Remarks
	gpm			g		psi			lbs	
1	2	3	4	5	6	7	8	9	10	11
E 303-753	58.1	D1/1	5EX2	91	SAE 2½, - 16 ³	36	1	V2.1425-23	19.6	-
E 303-766¹	92.5	D1/2	10EX2	120	SAE 2½, - 16 ³	36	1	V2.1425-26	19.6	-
E 303-768¹	132.1	D1/3	16EX2	130	SAE 2½, - 16 ³	36	1	V2.1425-28	19.6	-
E 503-753	92.5	D2/1	5EX2	150	SAE 2½, - 16 ³	36	1	V2.1440-23	25.8	-
E 503-766¹	142.7	D2/2	10EX2	200	SAE 2½, - 16 ³	36	1	V2.1440-26	25.8	-
E 503-768¹	198.1	D2/3	16EX2	200	SAE 2½, - 16 ³	36	1	V2.1440-28	25.8	-
E 703-753	132.1	D3/1	5EX2	230	SAE 2½, - 16 ³	36	1	V2.1460-23	34.0	-
E 703-766¹	195.5	D3/2	10EX2	300	SAE 2½, - 16 ³	36	1	V2.1460-26	34.0	-
E 703-768¹	237.8	D3/3	16EX2	310	SAE 2½, - 16 ³	36	1	V2.1460-28	34.0	-

¹ Preferred type, no minimum order quantity required

² The individual flow rates must be matched to the connections

³ Corresponds to 1⁵/₁₆-12 UN-2B / connection plugged with locking screw

All filters are delivered with a plugged clogging indicator connection M12 x 1.5 mm (mounting holes for differential pressure switches on request). As clogging indicators either manometers or electrical pressure switches can be used. Two different head pieces with three various connecting options are available. All filters can also be supplied with an outlet diffuser. Optional extension pipes adapt the filter length to various tank depths.

For the appropriate clogging indicators see catalog sheet 60.20.

Remarks:

- › The switching pressure of the electrical pressure switch has always to be lower than the cracking pressure of the by-pass valve (see Selection Chart, column 7).
- › Clogging indicators are optional and always delivered detached from the filter.
- › The filters listed in this chart are standard filters. Other designs available on request.

Dimensions in mm

Version with 4 connections

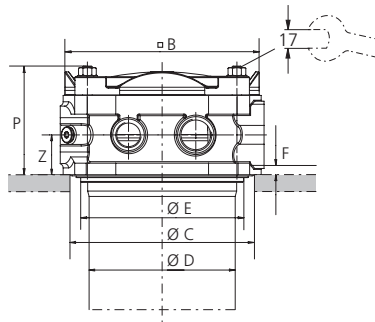

Tank surface sealing with O-ring N007.1806 (included in basic equipment)

Version with 2 connections

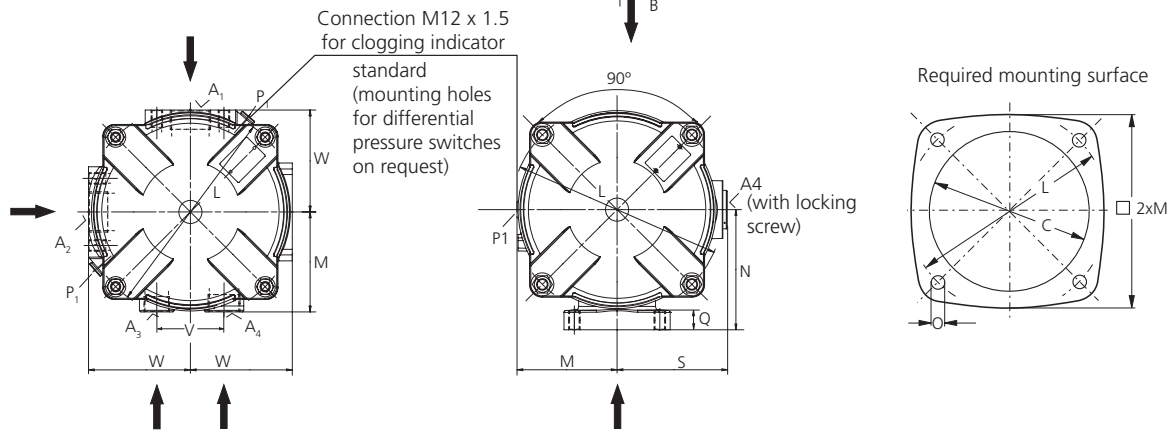
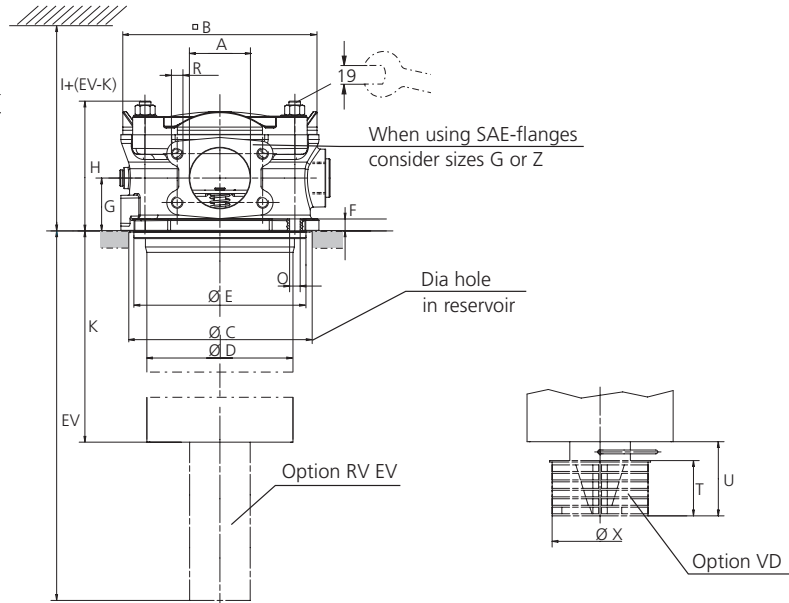

Measurements in mm

Type	A	B	C	D	E	F	G	H	I	K	L	M	N	O	P
E 303	see	182	180	152	179	12	55	133	400	276	220	104	125	11.5*	113
E 503	Selection	182	180	152	179	12	55	133	550	430	220	104	125	11.5*	113
E 703	Chart	182	180	152	179	12	55	133	810	636	220	104	125	11.5*	113
Type	Q	R	S	T	U	V	W	X	Z						
E 303	20	M12	115	58	79	70	106	100	41.5						
E 503	20	M12	115	58	79	70	106	100	41.5						
E 703	20	M12	115	58	79	70	106	100	41.5						

* For M10

Symbols

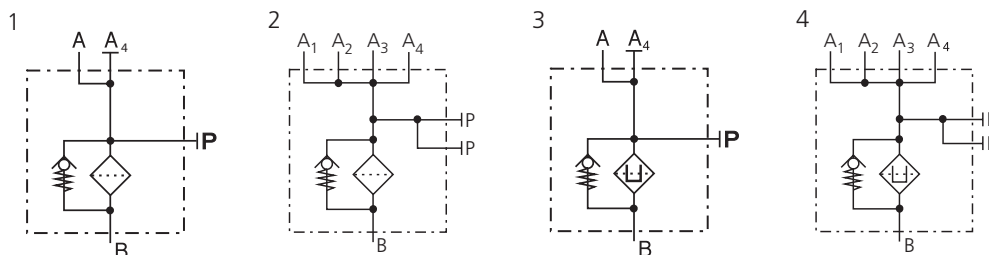

Dimensions in inch

Tank surface sealing with O-ring N007.1806 (included in basic equipment)

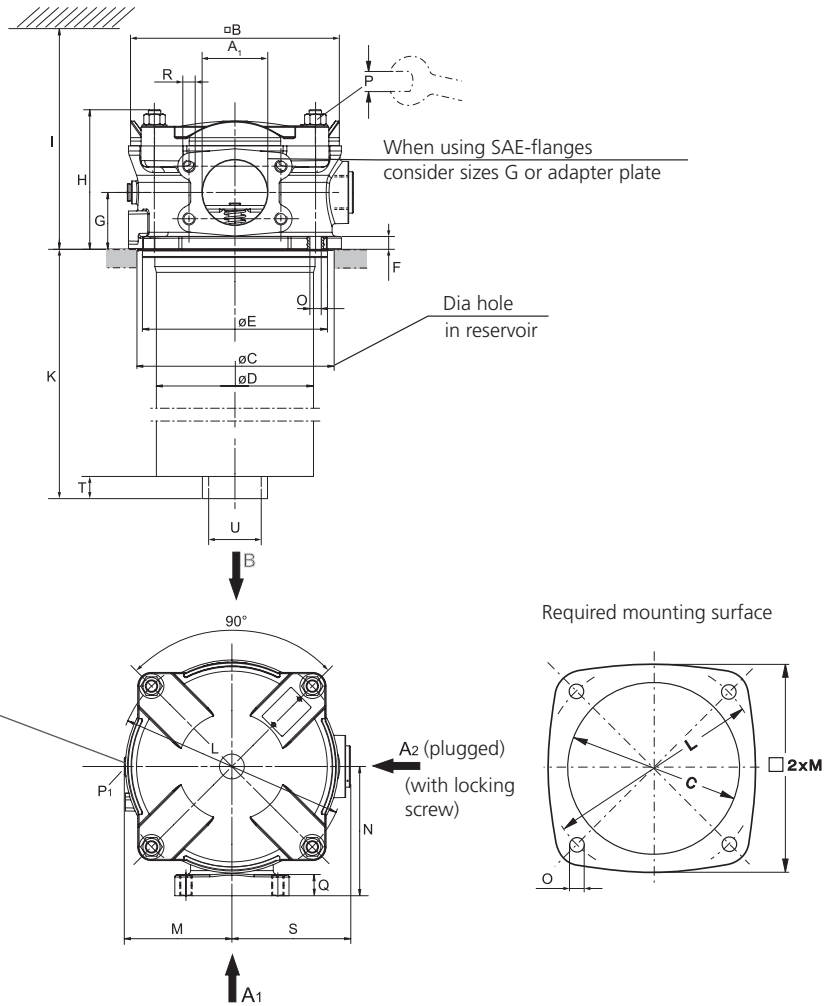

Measurements in inch

Type	A ₁ / A ₂	B	C	D	E	F	G	H	I	K	L	M	N
E 303	see	7.17	7.09	5.98	7.05	0.47	2.17	5.24	15.75	10.87	8.66	4.09	4.92
E 503	Selection	7.17	7.09	5.98	7.05	0.47	2.17	5.24	21.65	16.93	8.66	4.09	4.92
E 703	Chart	7.17	7.09	5.98	7.05	0.47	2.17	5.24	31.89	25.04	8.66	4.09	4.92

Type	O	P mm	Q	R	S	T	U						
E 303	0.45*	AF 19	0.79	M12	4.53	2.28	2½-8NPT						
E 503	0.45*	AF 19	0.79	M12	4.53	2.28	2½-8NPT						
E 703	0.45*	AF 19	0.79	M12	4.53	2.28	2½-8NPT						

* For M10

Symbols

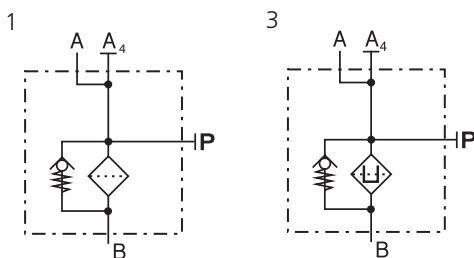

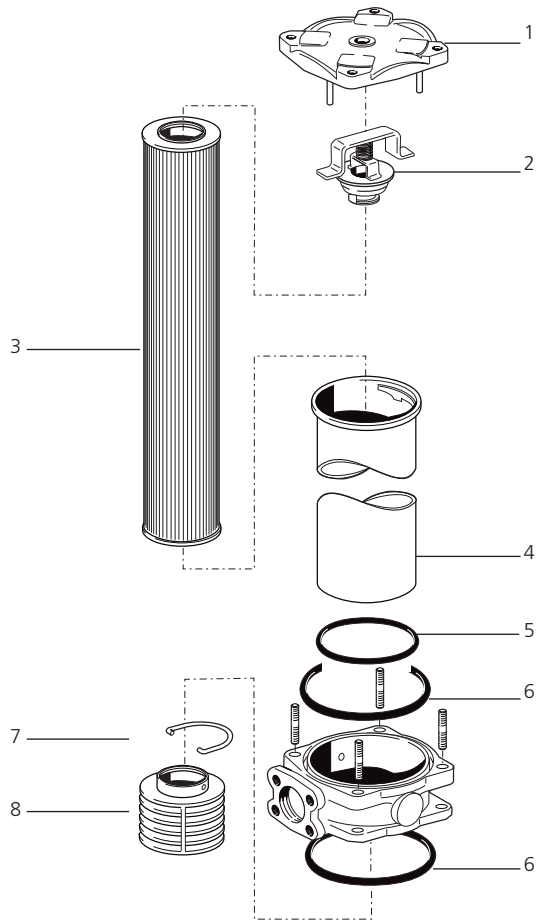

Pos.	Designation	Part No.
1	Cover assy (2 connections)	E 303.1200
1	Cover assy (4 connections)	E 703.2202
2	By-pass (2.5 bar / 36 psi)	E 703.1510
3	Replacement filter elements	see Chart. / col. 9
4	Filter bowl E 303*	E 303.1900
4	Filter bowl E 503*	E 503.1910
4	Filter bowl E 703*	E 703.1900
5	O-ring 145.42 x 5.33 mm 5.73 x 0.21 inch	N007.1455
6	O-ring 180 x 6 mm 7.09 x 0.24 inch	N007.1806
7	Clip (only option VD)	N026.0311
8	Diffuser (only option VD)	E 703.0701

*Please indicate options (VD, VDEV and RVEV respectively)

The functions of the complete filters as well as the outstanding features of the filter elements assured by ARGO-HYTOS can only be guaranteed if original ARGO-HYTOS spare parts are used.

Quality Assurance

Quality management according to DIN EN ISO 9001

To ensure constant quality in production and operation, ARGO-HYTOS filter elements undergo strict controls and tests according to the following ISO standards:

- ISO 2941 Verification of collapse / burst pressure rating
- ISO 2942 Verification of fabrication integrity (Bubble Point Test)
- ISO 2943 Verification of material compatibility with fluids
- ISO 3968 Evaluation of pressure drop versus flow characteristics
- ISO 16889 Multi-Pass-Test (evaluation of filter fineness and dirt-holding capacity)
- ISO 23181 Determination of resistance to flow fatigue using high viscosity fluid

Various quality controls during the production process guarantee the leakfree function and solidity of our filters.

Illustrations may sometimes differ from the original. ARGO-HYTOS is not responsible for any unintentional mistake in this specification sheet.