

High Pressure Filters
HD 314 · HD 414 · HD 614

Flangeable · Operating pressure up to 500 bar / 7250 psi · Nominal flow rate up to 400 l/min / 105.7 gpm



High Pressure Filter HD 414

Description
Application

In the high pressure circuits of hydraulic systems.

Performance features
Protection against wear:

By means of filter elements that even in full-flow filtration meet the highest demands regarding cleanliness classes.

Protection against malfunction:

 Through installation near to the control valves or other expensive components. The specific determined flow rate guarantees a closed by-pass valve even at $\leq 200 \text{ mm}^2/\text{s}$ / 927 SUS (cold start condition).

Filter elements

Flow direction from outside to center.

The star-shaped pleating of the filter material results in:

- › large filter surfaces
- › low pressure drop
- › high dirt-holding capacities
- › long service life

Filter maintenance

By using a clogging indicator the correct moment for maintenance is stated and guarantees the optimum utilization of the filter life.

Materials

Filter head:	Spheroidal graphite cast iron (SGI)
Filter bowl:	Cold extruded steel
Coating:	Powder paint
Seals:	NBR (FPM on request)
Filter media:	EXAPOR®MAX 2 - inorganic multi-layer microfiber web
	Paper - cellulose web, impregnated with resin

Accessories

Electrical and / or optical clogging indicators are available - optionally with one or two switching points resp. temperature suppression.

Dimensions and technical data see catalog sheet 60.30.

Characteristics

Operating pressure

0 ... 315 bar / 4570 psi, min. 2×10^6 pressure cycles
Nominal pressure according to DIN 24550

0 ... 500 bar / 7250 psi, min. 10^4 pressure cycles
Quasi-static operating pressure

Permissible pressures for other numbers of cycles

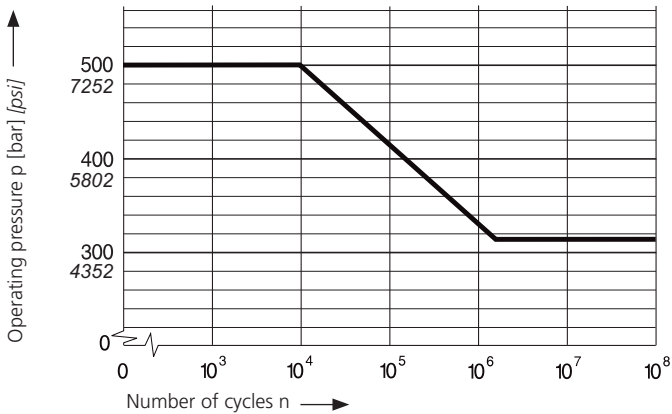

Nominal flow rate

Up to 400 l/min / 105,7 gpm (see Selection Chart, column 2).
The nominal flow rates indicated by ARGO-HYTOS are based on the following features:

- › closed by-pass valve at $v \leq 200 \text{ mm}^2/\text{s}$ / 927 SUS
- › element service life > 1000 operating hours at an average fluid contamination of 0.07 g per l/min / 0.27 g per gpm flow volume
- › flow velocity in the connection lines:
up to 250 bar $\leq 8 \text{ m/s}$ / up to 3626 psi $\leq 26.3 \text{ ft/s}$
> 250 bar $\leq 12 \text{ m/s}$ / > 3626 psi $\leq 39.4 \text{ ft/s}$

Filter fineness

5 $\mu\text{m(c)}$... 16 $\mu\text{m(c)}$
 β -values according to ISO 16889
(see Selection Chart, column 4 and diagram Dx).

Dirt-holding capacity

Values in g test dust ISO MTD according to ISO 16889
(see Selection Chart, column 5).

Hydraulic fluids

Mineral oil and biodegradable fluids
(HEES and HETG, see info-sheet 00.20).

Temperature range

-30 °C ... +100 °C (temporary -40 °C ... +120 °C)
-22 °F ... +212 °F (temporary -40 °F ... +248 °F)

Viscosity at nominal flow rate

- › at operating temperature: $v < 60 \text{ mm}^2/\text{s}$ / 280 SUS
- › as starting viscosity: $v_{\text{max}} = 1200 \text{ mm}^2/\text{s}$ / 5560 SUS
- › at initial operation:

The recommended starting viscosity can be read from the diagram D (pressure drop as a function of the kinematic viscosity) as follows: Find the 70% Δp of the cracking pressure of the by-pass valve on the vertical axis. Draw a horizontal line so that it intersects the Δp curve at a point. Read this point on the horizontal axis for the viscosity.

Mounting position

Preferably vertical, filter head on top.

Connection

2 x $\varnothing 31 \text{ mm}$ / 2 x $\varnothing 1.22 \text{ inch}$ on plain flange.

Diagrams

Δp -curves for complete filters in Selection Chart, column 3

D1 Pressure drop as a function of the **flow volume**
at $v = 35 \text{ mm}^2/\text{s}$ / 162 SUS (0 = casing empty)

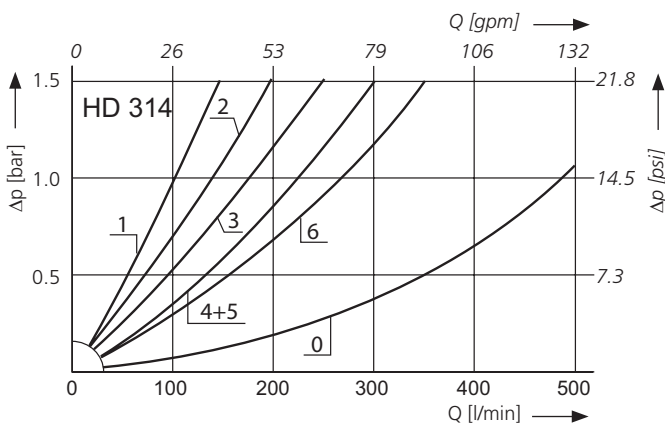

Pressure drop as a function of the **kinematic viscosity** at nominal flow

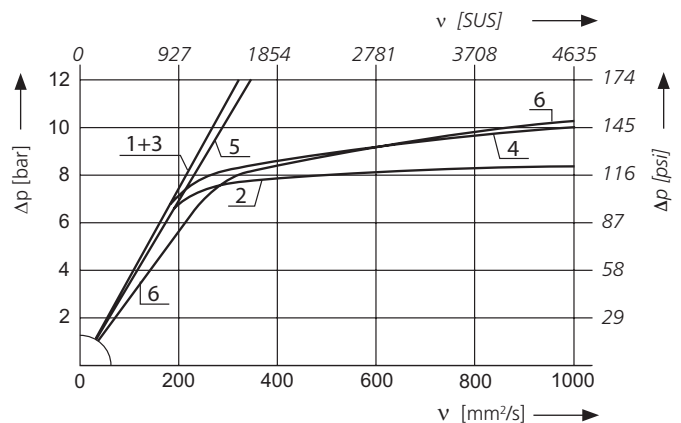

Δp-curves for complete filters in Selection Chart, column 3

D2 Pressure drop as a function of the **flow volume** at $v = 35 \text{ mm}^2/\text{s} / 162 \text{ SUS}$ (0 = casing empty)

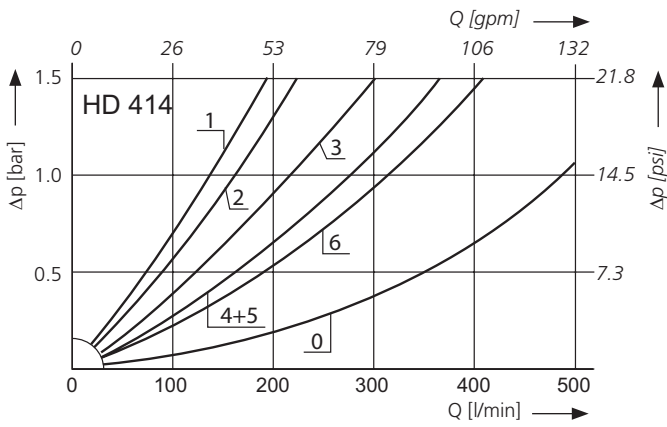

Pressure drop as a function of the **kinematic viscosity** at nominal flow

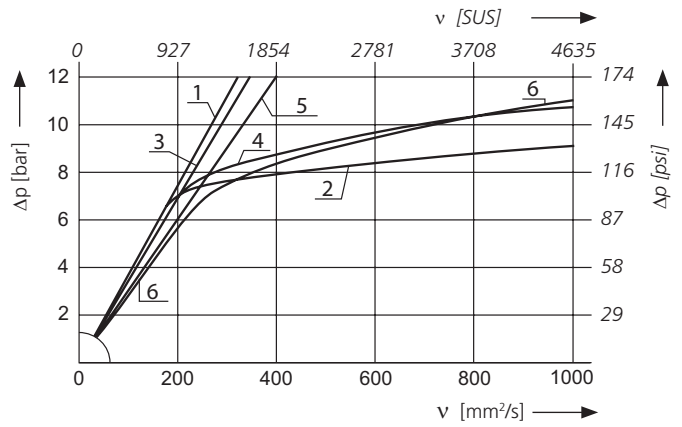

D3 Pressure drop as a function of the **flow volume** at $v = 35 \text{ mm}^2/\text{s} / 162 \text{ SUS}$ (0 = casing empty)

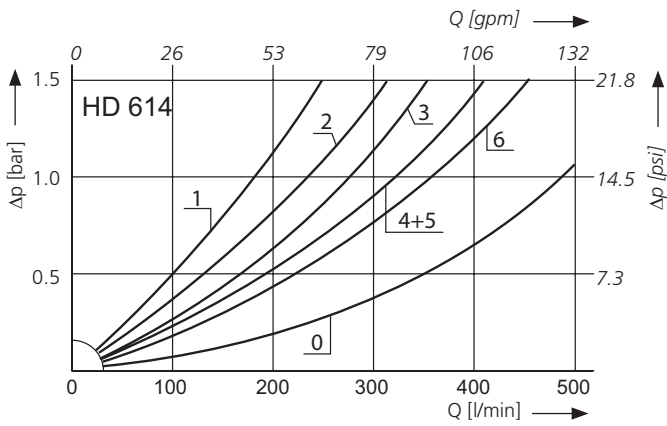

Pressure drop as a function of the **kinematic viscosity** at nominal flow

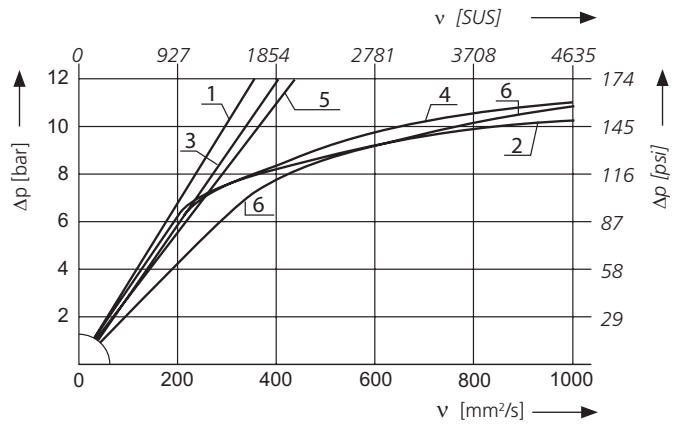

Filter fineness curves in Selection Chart, column 4

Dx Filtration ratio β as a function of particle size x obtained by the Multi-Pass Test according to ISO 16889

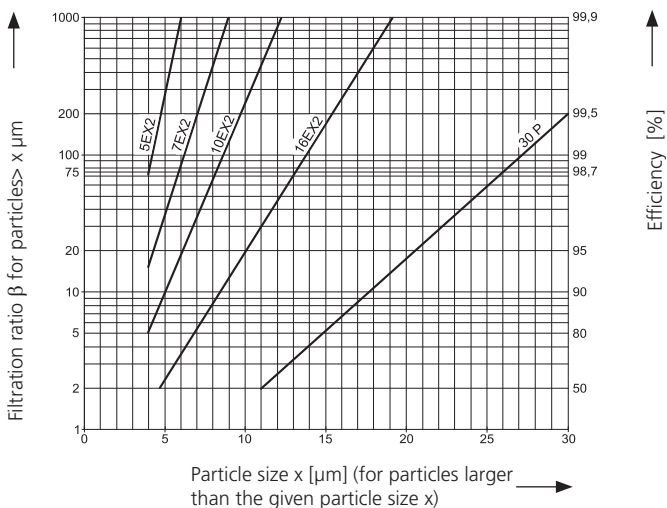

The abbreviations represent the following β -values resp. finenesses:

For EXAPOR®MAX2 and Paper elements:

- 5EX2 = $\bar{\beta}_{5(c)} = 200$ EXAPOR®MAX 2
- 7EX2 = $\bar{\beta}_{7(c)} = 200$ EXAPOR®MAX 2
- 10EX2 = $\bar{\beta}_{10(c)} = 200$ EXAPOR®MAX 2
- 16EX2 = $\bar{\beta}_{16(c)} = 200$ EXAPOR®MAX 2
- 30P = $\bar{\beta}_{30(c)} = 200$ Paper

Based on the structure of the filter media of the 30P paper elements, deviations from the printed curves are quite probable.

For screen elements:

- 40S = screen material with mesh size 40 μm
 - 60S = screen material with mesh size 60 μm
 - 100S = screen material with mesh size 100 μm
- Tolerances for mesh size according to DIN 4189

For special applications, finenesses differing from these curves are also available by using special composed filter media.

Dimensions

Version with electrical clogging indicator DG 041

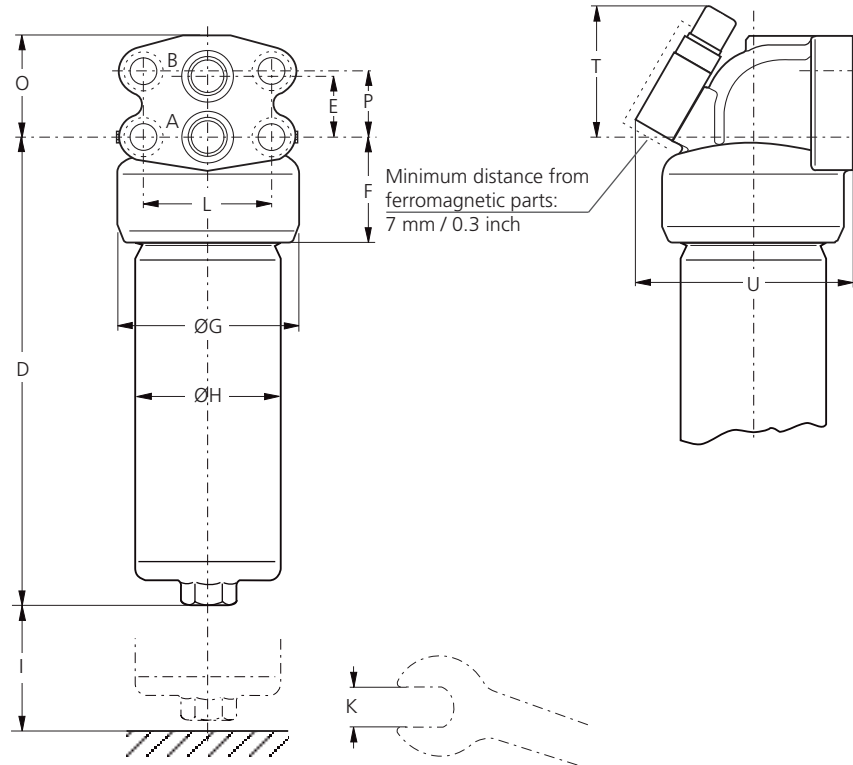

Clogging indicator optional:
Pressure holes plugged with screws

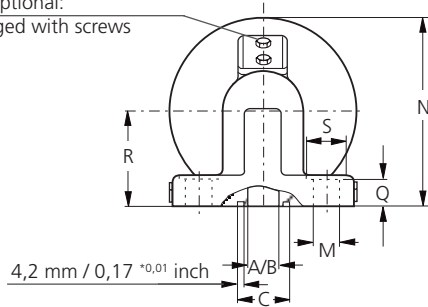

Measurements in mm

Type	A/B	C	D	E	F	G	H	I	K	L	M	N	O	P	Q	R	S	T	U
HD 314	Ø 31	44.4	263	52	82	138	109	80	AF 32	95	21.5	150	83	58	25	80	34	93	165
HD 414	Ø 31	44.4	325	52	82	138	109	80	AF 32	95	21.5	150	83	58	25	80	34	93	165
HD 614	Ø 31	44.4	426	52	82	138	109	80	AF 32	95	21.5	150	83	58	25	80	34	93	165

Measurements in inch

Type	A/B	C	D	E	F	G	H	I	K	L	M	N	O	P	Q	R
HD 314	Ø 1.22	1.75	10.35	2.05	3.23	5.43	4.29	3.15	AF 32	3.74	0.85	5.91	3.27	2.28	0.98	3.15
HD 414	Ø 1.22	1.75	12.80	2.05	3.23	5.43	4.29	3.15	AF 32	3.74	0.85	5.91	3.27	2.28	0.98	3.15
HD 614	Ø 1.22	1.75	16.77	2.05	3.23	5.43	4.29	3.15	AF 32	3.74	0.85	5.91	3.27	2.28	0.98	3.15

Type	S	T	U
HD 314	1.34	3.66	6.50
HD 414	1.34	3.66	6.50
HD 614	1.34	3.66	6.50

Symbols

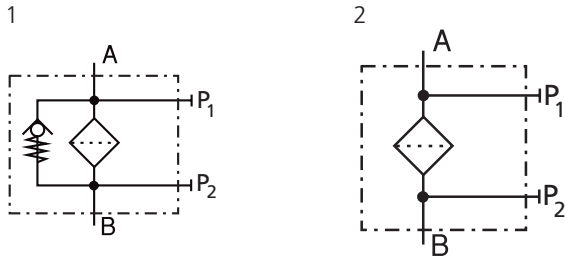

Spare Parts

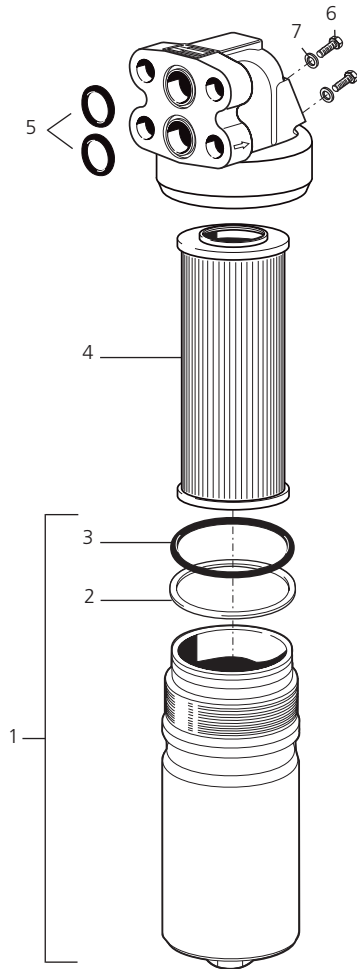

Pos.	Designation	Part No.
1	Filter bowl HD 314 (with Pos. 2 und 3)	HD 250.0701
1	Filter bowl HD 414 (with Pos. 2 und 3)	HD 451.0702
1	Filter bowl HD 614 (with Pos. 2 und 3)	HD 619.0701
2	Back-ring	HD 255.0102
3	O-ring 94.84 x 3.53 mm 3.73 x 0.14 inch	N007.0953
4	Replacement filter element	s. Chart / col. 9
5	O-ring 37.69 x 3.53* mm 1.48 x 0.14* inch	N007.0384
6	Hexagonal head screw M4 x 8 DIN 933-8.8	11385800
7	Bonded Seal 4.1 x 7.2 x 1 mm 0.16 x 0.28 x 0.04 inch	12504600

* Not supplied with filter - has to be ordered separately

The functions of the complete filters as well as the outstanding features of the filter elements assured by ARGO-HYTOS can only be guaranteed if original ARGO-HYTOS spare parts are used.

Quality Assurance

Quality management according to DIN EN ISO 9001

To ensure constant quality in production and operation, ARGO-HYTOS filter elements undergo strict controls and tests according to the following ISO standards:

ISO 2941	Verification of collapse / burst pressure rating
ISO 2942	Verification of fabrication integrity (Bubble Point Test)
ISO 2943	Verification of material compatibility with fluids
ISO 3968	Evaluation of pressure drop versus flow characteristics
ISO 16889	Multi-Pass-Test (evaluation of filter fineness and dirt-holding capacity)
ISO 23181	Determination of resistance to flow fatigue using high viscosity fluid

Before release into the series production the filter casing is tested for fatigue strength in our pressure pulse test rig. Various quality controls during the production process guarantee the leakfree function and solidity of our filters.

Illustrations may sometimes differ from the original. ARGO-HYTOS is not responsible for any unintentional mistake in this specification sheet