

Explosion Proof Proportional Directional Control Valve

PRMX2-06

Size 06 (D03) • Q_{max} 28 l/min (7.4 GPM) • p_{max} 350 bar (5100 PSI)

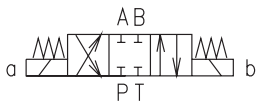
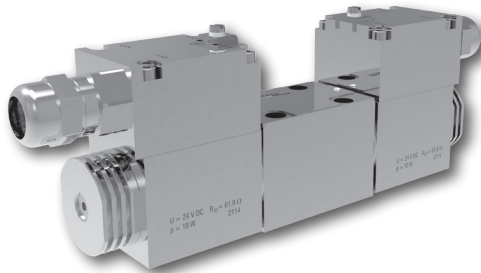

ISO 4401-03-02-0-05

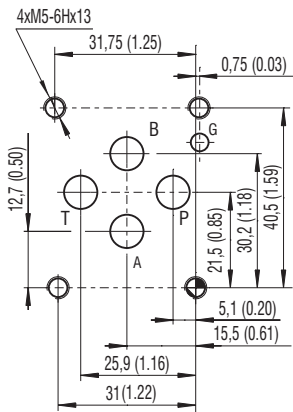

Ports P, A, B, T - max. \varnothing 7.5 mm (0.29 in)

Technical Features

- Hydraulic, proportional, spool-type, directional control valve with cast iron body and connection according to ISO 4401 and DIN 24340 (CETOP 03)
- Maximum operating pressure 350 bar (P, A, B ports) / 210 bar (T port)
- Solenoid coil certification ATEX (Directive 2014/34/EU) and IECEx, valid for mines and environments with potentially explosive atmospheres consisting of gases or dust
- Coil protection by encapsulation "m" for gases and by flameproof enclosure "t" for dust
- Robust design resistant to mechanical damage
- Protection against static discharge by grounding the valve surface
- Valves applicable to temperature class T4 (135 °C) depending on maximum ambient temperature
- Optional coil supply voltage, spool type and type of manual override
- The valve is zinc coated for 520 h corrosion protection in NSS acc. to ISO 9227 and as protection against ignition spark in the event of mechanical impact

Product Description

Direct-acting, proportional, spool-type, directional control valve operated by solenoid. The valve is designed for continuous control of volumetric flow, proportional to the electrical control signal. In practice, the valve is used to continuously control the speed and direction of the hydraulic cylinder piston rod or hydraulic motor shaft speed. The valve is certified for use in potentially explosive atmospheres of gases, vapors, dusts and flammable particles with a high protection level EPL = b. A suitable electronic control unit (not included) should be used to control the valve, which must meet the required degree of protection or be located outside the explosive atmosphere.

Use of the valve in potentially explosive atmospheres

	EPS14ATEX1744 X	IECEx EPS14.0064 X
DC	Ex I M2 Ex eb mb I Mb	Ex eb mb I Mb
	Ex II 2G Ex eb mb IIC T4 Gb	Ex eb mb IIC T4 Gb
	Ex II 2D Ex tb IIIC T135°C Db	Ex tb IIC T135°C Db

Ordering Code

PRMX2-06 [] / [] - [] **B4** [] [] [] - **B** []

<p>Explosion proof Proportional Directional Control Valve</p> <p>Valve size</p> <p>Spool symbols see the table „Spool Symbols“</p> <p>Nominal flow rate at $\Delta p = 10$ bar (145 PSI) 10 l/min (2.6 GPM) 10 20 l/min (5.3 GPM) 20 28 l/min (7.4 GPM) 28</p> <p>Supply voltage / limit current (I_G) 12 V DC / 1.37 A 12 24 V DC / 0.65 A 24</p> <p>Temperature class - solenoid nominal input power Class T4 - 18 W</p>	<p>Certifications of valve No designation ATEX, IECEx A IIECEx for Australia and New Zealand E EAC for EAEU* States</p> <p>Surface treatment zinc-coated (ZnNi), ISO 9227 (520 h)</p> <p>Seals NBR</p> <p>Manual override standard detent assembly</p> <p>Cable length without cable 3 m 8 m</p>
---	---

No designation N7

*EAEU= Eurasian Economic Union, certificate according to TR TS 012/2011 valid for the Russian Federation, Belarus, Armenia, Kazakhstan and Kyrgyzstan.
 - For proportional valves with two solenoids, one solenoid must be de-energized before the other solenoid can be charged.
 - Mounting bolts M5x45 DIN 912 10.9 (ISO 4762) or studs must be ordered separately.
 - Besides the valve versions shown, which are the most frequently used, other special versions are available.
 - Consult our technical department for their identification, feasibility and operating limits.

Technical Data

Valve size		06 (D03)	
Max. operating pressure at ports P, A, B	bar (PSI)	350 (5080)	
Maximum operating pressure at port T	bar (PSI)	210 (3050)	
Maximal flow at $\Delta p=10$ bar (145 PSI)	l/min (GPM)	10 (2.6), 20 (5.3), 28 (7.4)	
Fluid temperature range (NBR)	°C (°F)	-30 ... +70 (-22 ... +158)	
Ambient temperature max.	°C (°F)	-30 ... +60 (-22 ... +140)	
Hysteresis	%	< 6	
Weight	valve with 1 solenoid	2.52 (5.56)	
	valve with 2 solenoids	3.97 (8.75)	
Technical Data - Explosion Proof Solenoid			
Available nominal voltages U_N	V DC	12	24
Available nominal input power	W	18	
Supply voltage fluctuations		$U_N \pm 10\%$	
Enclosure type acc. to EN 60529		IP66 / IP68*	
*Test procedure IP68: Pressure 1 m under water, test duration 24 h. The indicated IP protection level is only achieved if the cable is properly mounted.			
Limit current	A	1.37	0.65
Rated resistance at 20 °C (68 °F)	Ω	7.7	32.3
	Datasheet	Type	
General information	GI_0060	Products and operating conditions	
Operating Instructions	15183		
Mounting surface	SMT_0019	Size 06	
Spare parts	SP_8010		

Spool Symbols

Typ	Symbol	Typ	Symbol
2Z51		2Y51	
2Z11		2Y11	
3Z11		3Y11	

Manual Override in millimeters (inches)

No designation - standard	N7 - detent assembly

In case of solenoid malfunction or power failure, the spool of the valve can be shifted by manual override as long as the pressure in port T does not exceed 25 bar (363 PSI). For alternative manual overrides contact our technical support.

Characteristics measured at $v = 32 \text{ mm}^2/\text{s}$ (156 SUS)

Flow characteristic

$\Delta p = 10 \text{ bar}$ (145 PSI)

Flow direction:

$P \rightarrow A / B \rightarrow T$ or $P \rightarrow B / A \rightarrow T$

Nominal flow 10, 20, 28 l/min	(2.6)	10	(5.3)	20	(7.4)	28
Flow Q [l/min (GPM)]	(2.0)	7,5	(4.0)	15	(5.6)	21
	(1.3)	5,0	(2.6)	10	(3.7)	14
	(0.7)	2,5	(1.3)	5	(1.9)	7
	0	0	0	0	0	0
	(-0.7)	-2,5	(-1.3)	-5	(-1.9)	-7
	(-1.3)	-5,0	(-2.6)	-10	(-3.7)	-14
	(-2.0)	-7,5	(-4.0)	-15	(-5.6)	-21
	(-2.6)	-10	(-5.3)	-20	(-7.4)	-28

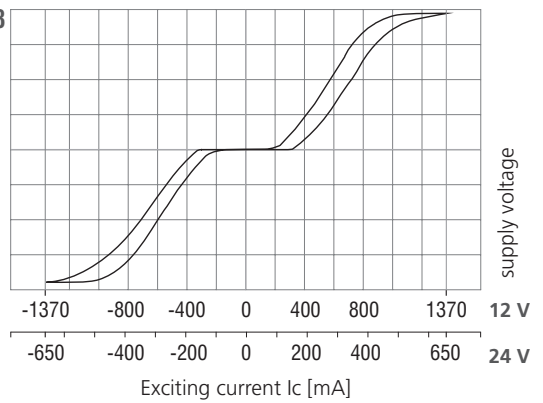

Operating limits

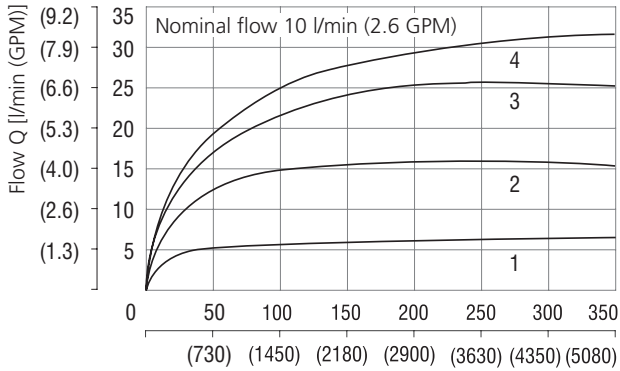

Solenoid current:	
1	40 %
2	60 %
3	80 %
4	100 %

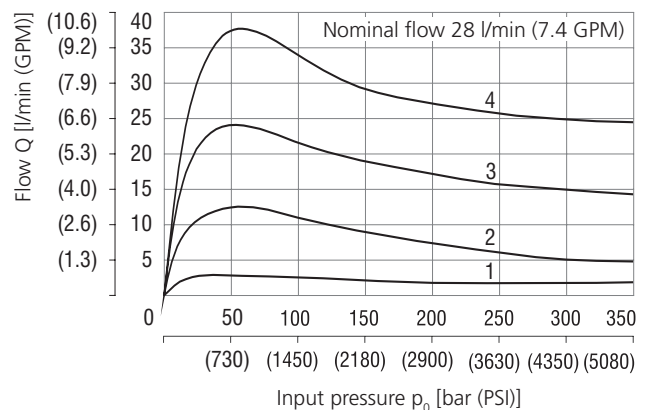
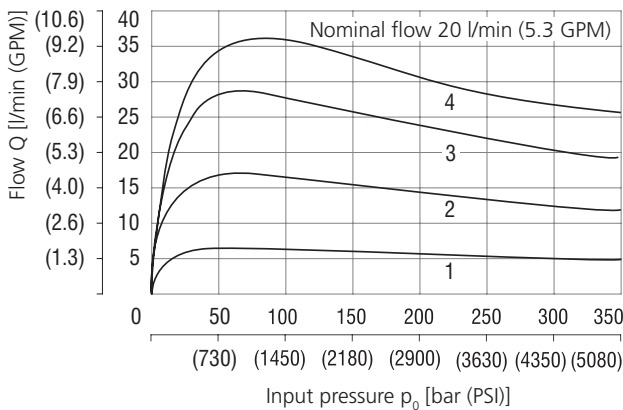

Dimensions in millimeters (inches)

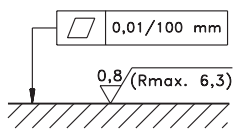

Required surface quality of the counterpart

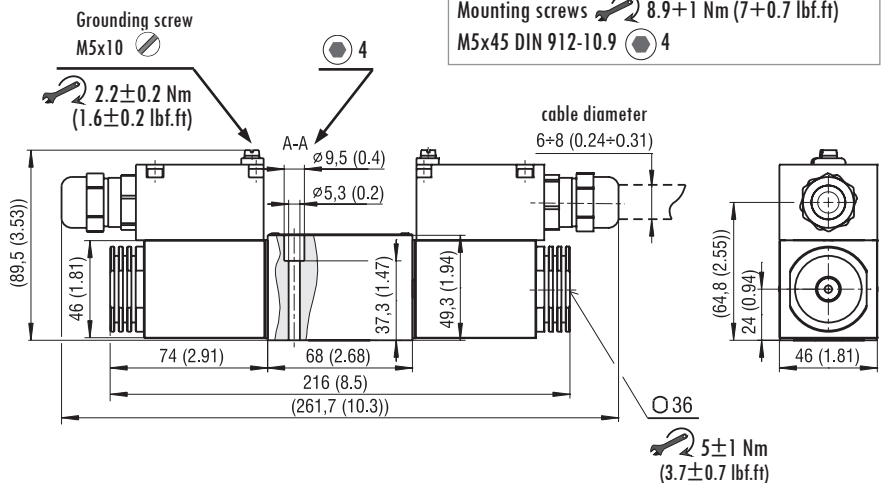
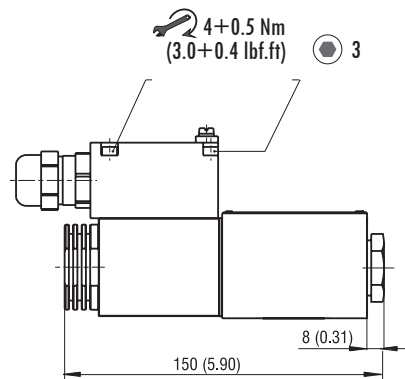
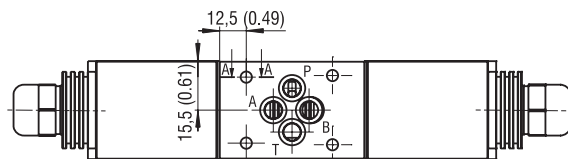

SPARE PARTS

Position	Component name	Description	Ordering number
1	Coil nut	Nut	45904300
3	Set	Nut sealing	
4	Sealing ring actuating system-coil	O-ring 22x1.5 VMQ 50 (silicone)	
2	Coil nut with manual override N7	Nut	45904200
3	Set	Nut sealing	
4	Sealing ring actuating system-coil	O-ring 22x1.5 VMQ 50 (silicone)	
5	Sealing ring of terminal box cover	O-ring 46x2 VMQ (silicone)	34950700
6	Set of seals	4x Square ring 9.25x1.68 NBR	15845200
7	Valve mounting screws	4x M5x45 DIN 912 10.9	15845100

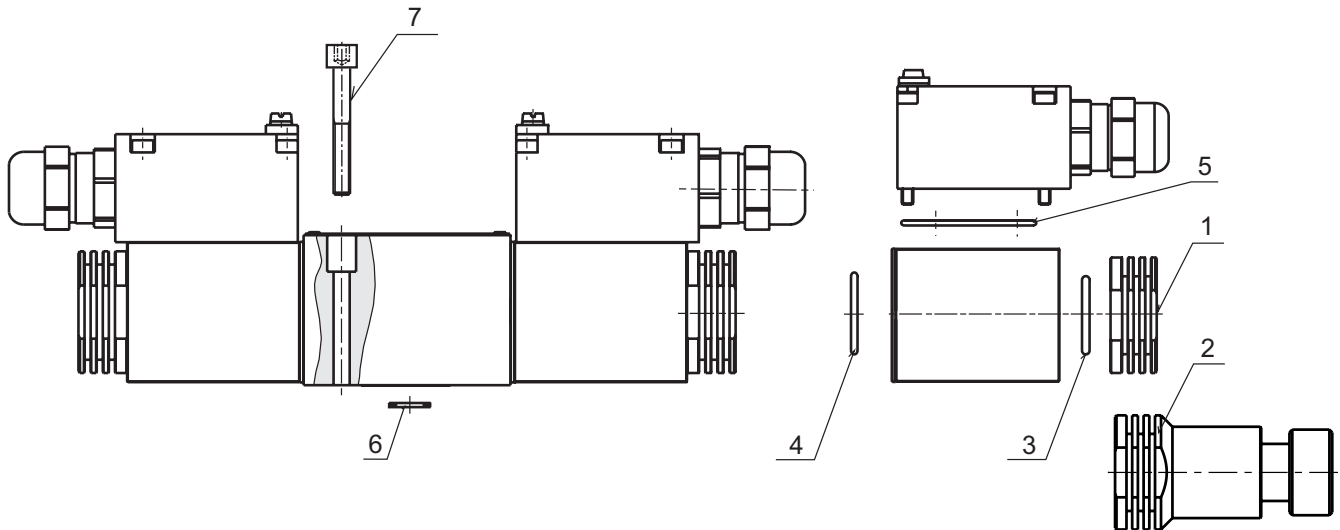

Information for Customers

- › Before installing the product, please read the Product Instructions for Use, which is available in full on the manufacturer's website (www.argo-hytos.com) near the data sheet. Please also pay attention to the chapter describing the target user group, their professional qualifications and medical fitness to install, use and repair the product.
- › The product may only be used in the zones indicated, otherwise there is a risk of initiating an explosion.

Area of application

Equipment - group I – MINES	Equipment - group II (IIG) - GAS		Equipment - group III (IID) - DUST	
Category M1 – NO	Zone 0 - NO		Zone 20 - NO	
Category M2 (the device remains switched off)	Zone 1	IIA (propane)	Zone 21 Zone 22	IIA (combustible particles)
	Zone 2	IIB (ethylene)		IIIB (non-conductive dust)
		IIC (hydrogen)		IIIC (conductive dust)

- › For use in the temperature class, the maximum ambient temperature (see technical data table) must be observed for a given coil input (18 W), the maximum temperature of the working fluid 70 °C and the nominal voltage of the coil supply.
- › The user must ensure free heat dissipation from the valve surface. The surface must not be covered, exposed to a heat source or direct sunlight. When mounting the valves in groups, observe the minimum distances specified in the Instructions for Use.
- › A certified cable of temperature insulation class corresponding to the application temperature class must be used to the electrical connection of coil with DC supplying.
- › The valve surface must be grounded using the screw on the terminal box cover of coil to prevent electrostatic discharge.
- › It is forbidden to install, dismantle or repair the product in an explosive atmosphere. Repairs to the product shall be carried out by the manufacturer, except for repairs permitted by the user under the conditions specified in the Instructions for Use.
- › Attention! The surface of the coil and the valve gets hot during operation. There is a risk of skin burns if touched.