

2-Way Flow Regulator with Reverse Flow Check, Pressure Compensated, Subplate Mounted

VSS2-206

Size 06 (D03) • Q_{max} 32 l/min (9 GPM) • p_{max} 320 bar (4600 PSI)



with internal pilot

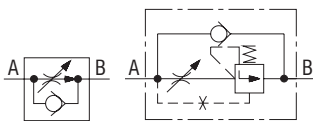

with external pilot

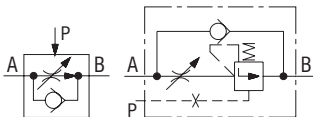

ISO 4401-03-02-0-05

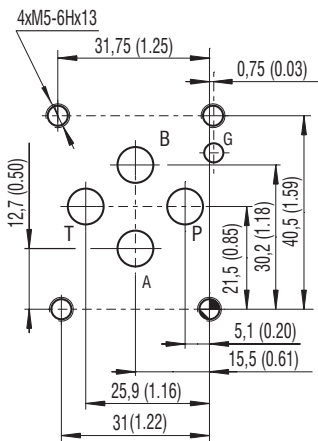

Ports P, A, B, T max. \varnothing 7.5 mm (0.29 in)

Technical Features

- › Subplate mounting interface acc. to ISO 4401, DIN 24340 (CETOP 03)
- › Set flow rate independent of load pressure and temperature changes
- › Meter-in, meter-out or bleed-off flow control
- › Externally or internally piloted pressure compensator
- › Adjusted flow rate depends on the orifice area and adjusted differential pressure
- › Wide range of flow rate options
- › Quiet and modulated response to load changes
- › Adjustment option with non-lockable or lockable cylindrical
- › Fine low-torque adjustment
- › In the standard version, the sandwich plate of valve is phosphated for basic surface corrosion protection and as preparation for painting. Steel parts are zinc-coated for corrosion protection 240 h in NSS acc. to ISO 9227.
- › Enhanced surface protection for mobile applications is available. The sandwich plate and steel parts are zinc-coated with corrosion protection 520 h in NSS

Functional Description

Pressure compensated flow control valves **VSS2-206** are designed to provide adjustable, controlled flow rate independently of changes in pressure and temperature.

The flow control valve consists of a housing, a throttling spool, an internal spring, the pressure compensator and a hand screw for adjustment.

Flow control valve **VSS2-206-xxQ/JxO** - internally piloted pressure compensator:

The valve senses load pressure inside the valve. Flow throttling in direction A to B can be adjusted by the hand screw. To ensure flow rate stability in port B, a pressure compensator is located behind the throttling area.

Flow control valve **VSS2-206-xxQ/JxA** - externally piloted pressure compensator:

The mounting surface area of the valve is connected to an external load sensing port P. This arrangement enables external piloting of the pressure compensator. The function is described by the circuit diagram shown.

Technical Data

Valve size		06 (D03)					
Max. flow	l/min (GPM)	32 (8.5)					
Max. operating pressure	bar (PSI)	320 (4640)					
Nominal flow rates	l/min (GPM)	0.6 (0.2)	1.6 (0.4)	3.2 (0.8)	6.3 (1.7)	16 (4.2)	32 (8.5)
Min. flow rates	cm ³ /min (inch ³ /min)	10 (0.6)	15 (0.9)	20 (1.2)	25 (1.5)	60 (3.7)	250 (15.3)
Fluid temperature range (NBR)	°C (°F)	-30 ... +100 (-22 ... +212)					
Fluid temperature range (FPM)	°C (°F)	-20 ... +120 (-4 ... +248)					
Maximum degree of fluid contamination	for Q ≤ (1 l/min) for Q > (1 l/min)	Class 20/17/14 according to ISO 4406 Class 21/18/15 according to ISO 4406					
Max. flow rate variation at pressure change (for Q > 2.5 Q _{min} and p = 6...100% p _{max})	%	± 5					
Weight	kg (lbs)	1.1 (2.43)					
General information		Datasheet		Type			
GI_0060		SMT_0019		Products and operating conditions			
SMT_0019		SP_8010		ISO 4401-03-02-0-05 DIN 2430 (CETOP 03)			
SP_8010							

Characteristics measured at v = 32 mm²/s (156 SUS)

Regulated flow related to input pressure

Model 0.6Q, 1.6Q, 3.2Q

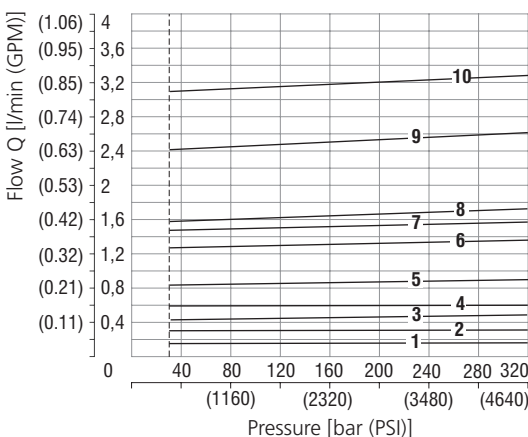

No.	Model
1	0.6Q
2	0.6Q
3	0.6Q
	1.6Q
4	1.6Q
	3.2Q
5	0.6Q
6	1.6Q
7	1.6Q
8	3.2Q
9	1.6Q
10	3.2Q
10	3.2Q

Model 6.3Q, 16Q, 32Q

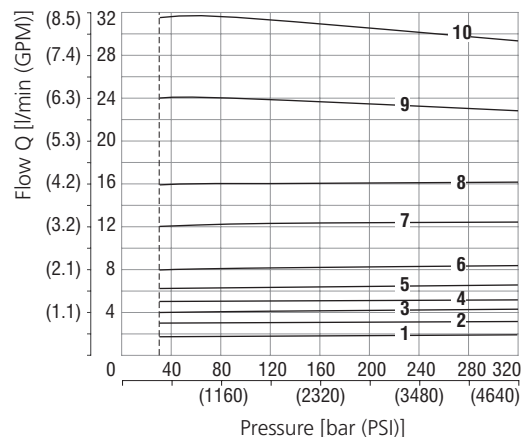

No.	Model
1	6.3Q
2	6.3Q
3	16Q
4	6.3Q
5	6.3Q
6	16Q
7	32Q
8	16Q
9	32Q
10	32Q

Characteristics measured at $v = 32 \text{ mm}^2/\text{s}$ (156 SUS)

Flow rate related to indicated scale

Flow direction A → B

Model 0.6Q, 1.6Q, 3.2Q

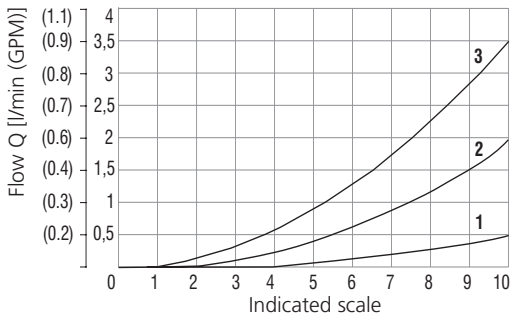

Flow control A → B	
No.	Model
1	VSS2-206-0.6Q-xx
2	VSS2-206-1.6Q-xx
3	VSS2-206-3.2Q-xx
4	VSS2-206-6.3Q-xx
5	VSS2-206-16Q-xx
6	VSS2-206-32Q-xx

Model 6.3Q, 16Q, 32Q

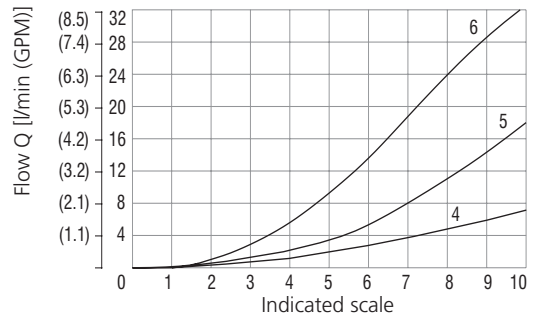

Pressure drop related to flow rate

Free flow check valve B → A

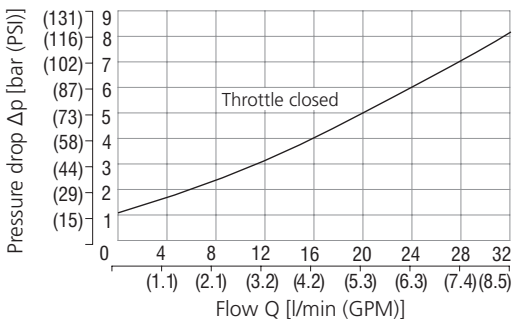

Set flow difference related to temperature

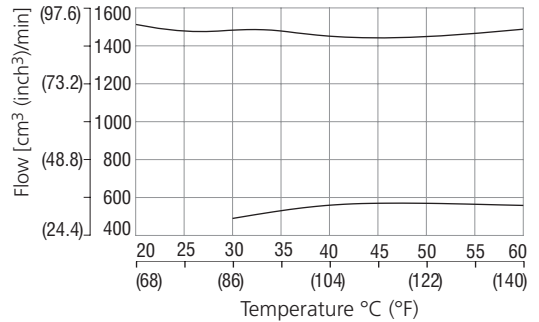

Dimensions in millimeters (inches)

Flow control valve VSS2-206-x/JxAx-x
with externally piloted pressure compensator

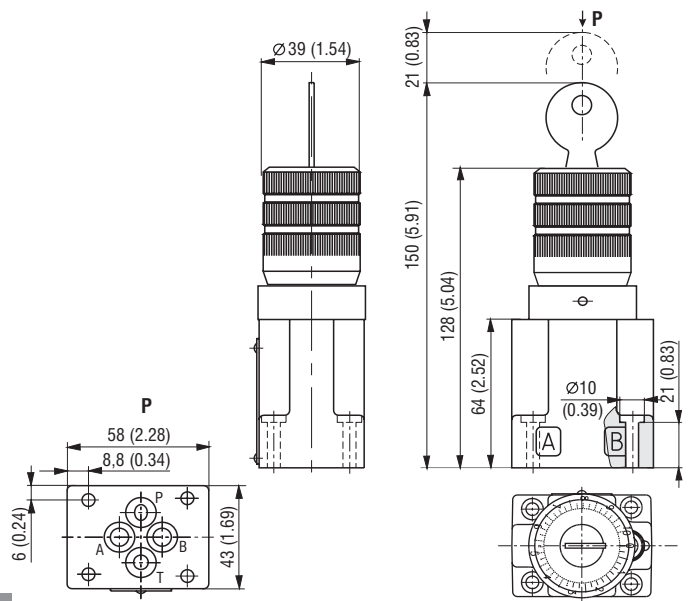
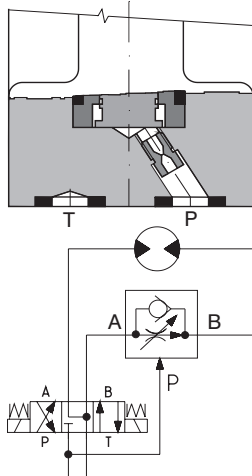

Ordering Code

2-Way flow regulator with reverse flow check, pressure compensated, subplate mounted

Valve size

Flow rate

- 0.6 l/min (0.2 GPM)
- 1.6 l/min (0.4 GPM)
- 3.2 l/min (0.9 GPM)
- 6.3 l/min (1.7 GPM)
- 16 l/min (4.2 GPM)
- 32 l/min (8.6 GPM)

Model

- subplate mounted - without check valve
- subplate mounted - with check valve

VSS2-2 06 - [] / [] [] [] [] - []

No designation

- body phosphated, steel parts
- zinc-coated (ZnCr-3), ISO 9227 (240 h)
- A** zinc-coated (ZnCr-3), ISO 9227 (240 h)
- B** zinc-coated (ZnNi), ISO 9227 (520 h)

Surface treatment

No designation

- V** NBR
- FPM (Viton)

Seals

Pressure compensator pilot design

- A** external pilot
- O** internal pilot

Adjustment option

- O** non-lockable cylindrical hand screw
- Z** lockable cylindrical hand screw